

# SKS 545N W3C 470 V16 SU

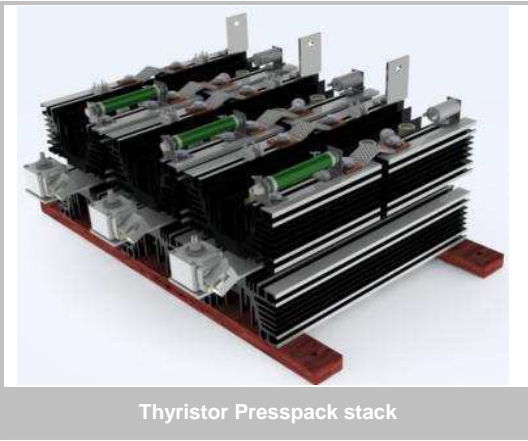

Electrical Characteristics						
Symbol	Conditions		min	typ	max	Unit
Electrical Data						
$I_{OUT}$	Maximum output current	$T_{AMBIENT} = 45^{\circ}C$ ; No overload		545		$A_{RMS}$
$V_{AC}$	Maximum AC voltage (+/-10%)			500		$V_{AC}$
$P_{TOTAL}$	Maximum stack power			470		kW
$P_{LOSS}$	Stack power loss ( $T_{AMBIENT} = 45^{\circ}C$ )					W

Environmental Data						
Symbol	Conditions		min	typ	max	Unit
Mechanical Data						
Drawing	SEMIKRON document number.revision.version			12051402.00.B		-
Weight	Approximate total weight			48.5		kg
Altitude	Installation altitude without derating				1 000	m
Protection	IEC 60529			IP00		-
Pollution Degree	EN 50178			2		-

## SEMISTACK® CLASSICS - W3C

Three phase reverse parallel thyristor converter

### Preliminary Data

Ordering No. 08785213  
Description SKS 545N W3C 470 V16 SU

### Features

- Non-isolated power stacks
- SKT 760/16
- Heatsink P11/415
- Natural cooling
- RC circuit included
- Fuses with microswitches

### Typical Applications

- Soft starters

### Remarks

This technical information specifies semiconductor devices but promises no characteristics. No warranty or guarantee, expressed or implied, is made regarding delivery, performance or suitability.

### Stack Protection

Symbol	Conditions		min	typ	max	Unit
RC Circuit						
Type	RC in parallel with each switch			-		-
R	Resistance (80W)			33		Ohm
C				0.47		$\mu F$

### Fuses

Size	1 fuse per phase, with microswitches		31		-
$I_{N RMS}$	Caliber		700		A
$U_N$	Nominal voltage (IEC)	690			V
$I^2t$	Total at $U_N$ at room temperature (approx. 20...25°C)			514.5	$kA^2s$

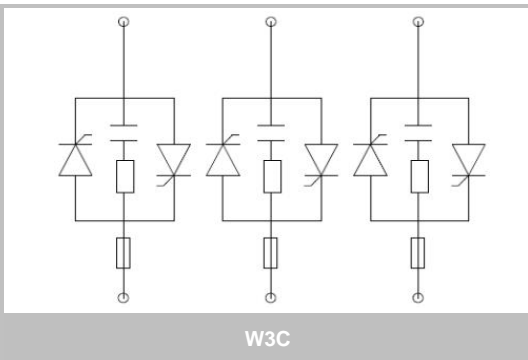

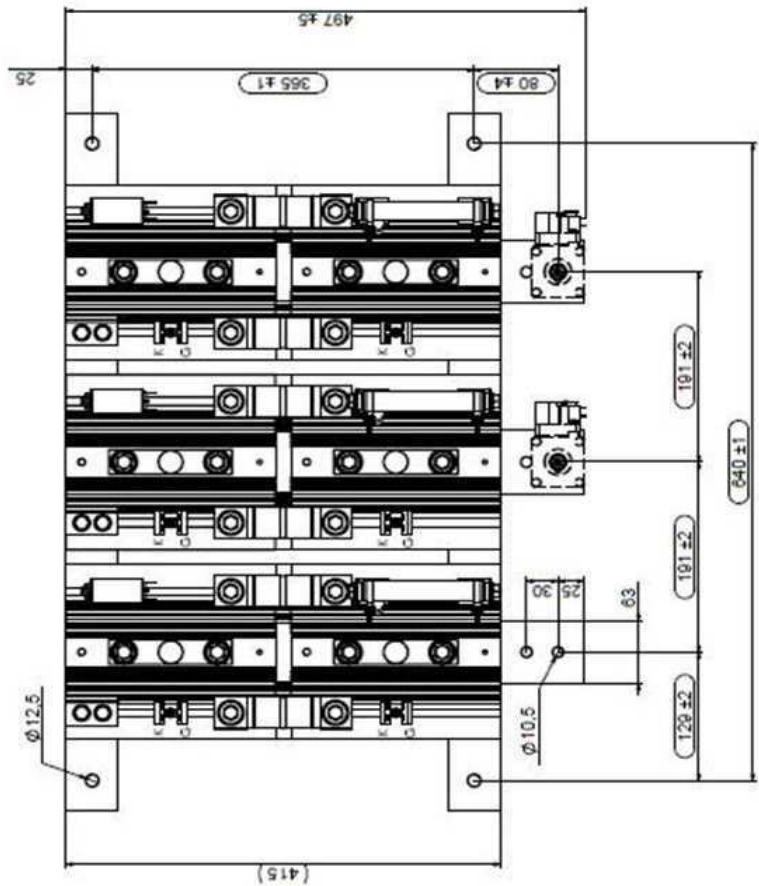
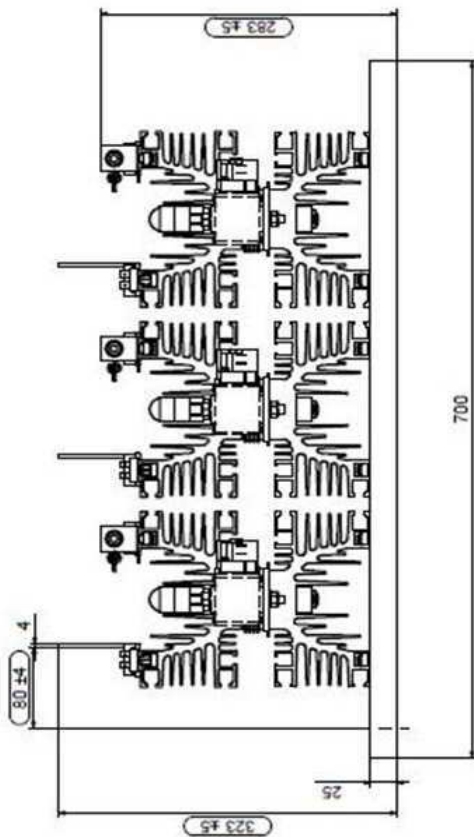
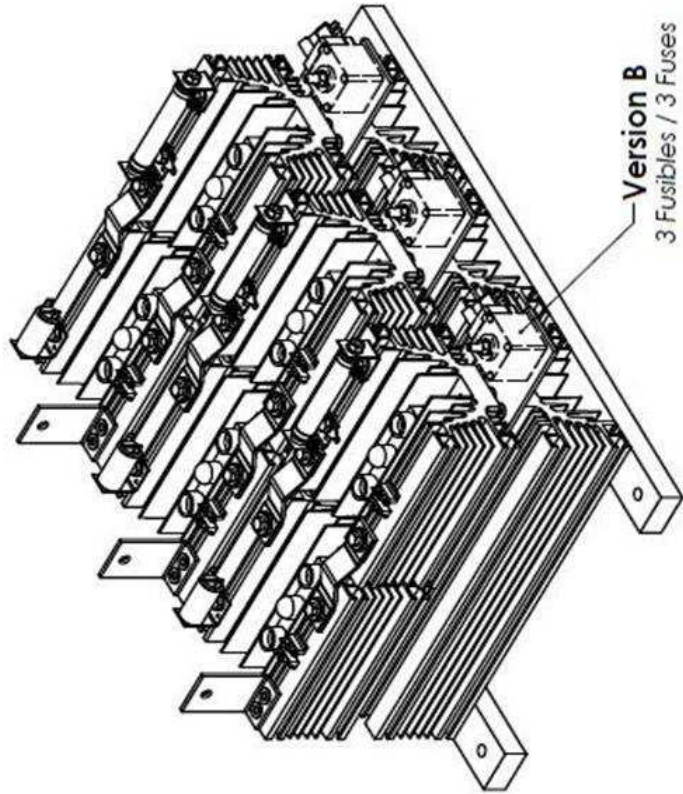
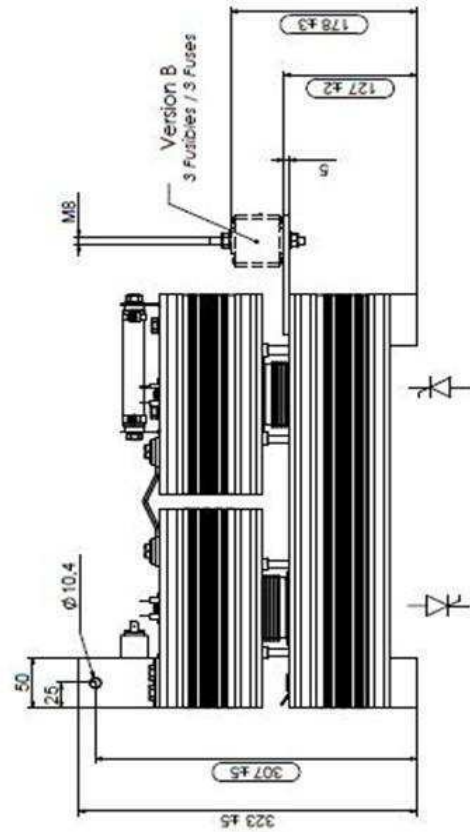

Dimensions

This technical information specifies semiconductor devices but promises no characteristics. No warranty or guarantee expressed or implied is made regarding delivery, performance or suitability.