

Diode Module stack

SEMISTACK® CLASSICS - B6U

Three phase uncontrolled rectifier

Preliminary data

Ordering No. 08785127

Description SKS 185F B6U 125 V16 SU

Features

- Isolated power stacks
- SKKD 100/16
- Heatsink P3/180
- Forced air cooling
- RC circuit included
- Fuses with microswitches
- Thermal trip included

Typical Applications

- Power supplies
- Rectifier for AC/DC motor control

Remarks

This technical information specifies semiconductor devices but promises no characteristics. No warranty or guarantee, expressed or implied, is made regarding delivery, performance or suitability.

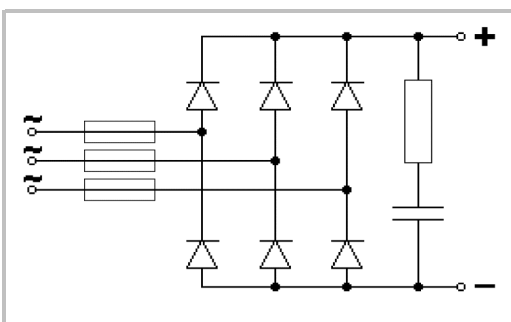

B6U

Electrical Characteristics

Symbol	Conditions		min	typ	max	Unit
Electrical Data						
I_D	Maximum DC current	$T_{AMBIENT} = 35^{\circ}C$; No overload		185		A
V_{AC}	Maximum AC voltage (+/-10%)			500		V_{AC}
V_{BUS}	DC Bus voltage			670		V_{DC}
P_{TOTAL}	Maximum stack power			125		kW
P_{LOSS}	Stack power loss ($T_{AMBIENT} = 35^{\circ}C$)					W

Environmental Data

Symbol	Conditions		min	typ	max	Unit
Mechanical Data						
Drawing	SEMIKRON document number.revision.version			12010312.00		-
Weight	Approximate total weight			5.3		kg
Altitude	Installation altitude without derating				1 000	m
Protection	IEC 60529			IP00		-
Pollution degree	EN 50178			2		-

Fan Data

Type	SEMIKRON fan designation	SKF 3-230-01	-
V_{FAN}	Fan voltage	230	V_{AC}
f_{FAN}	Fan frequency	50/60	Hz
I_{FAN}	Fan maximum input current	0.12/0.10	A
P_{FAN}	Fan power	15/14	W

Stack Protection

Symbol	Conditions		min	typ	max	Unit
RC Circuit						
Type	RC in parallel with bridge rectifier			1/2 RC15B		-
R	Resistance (11W)			68		Ohm
C				0.1		μF

Fuses

Size	1 fuse per phase, with microswitches	000	-
$I_{N RMS}$	Caliber	160	A
U_N	Nominal voltage (IEC)	690	V
I^2t	Total at U_N at room temperature (approx. 20...25°C)		17.44 kA ² s

Bimetal Thermal Trip

T_S	Switching temperature over which thermal trip is open		80	$^{\circ}C$
$I_{TC MAX}$	Maximum permissible current		1	A
	at 30Vdc		3	A

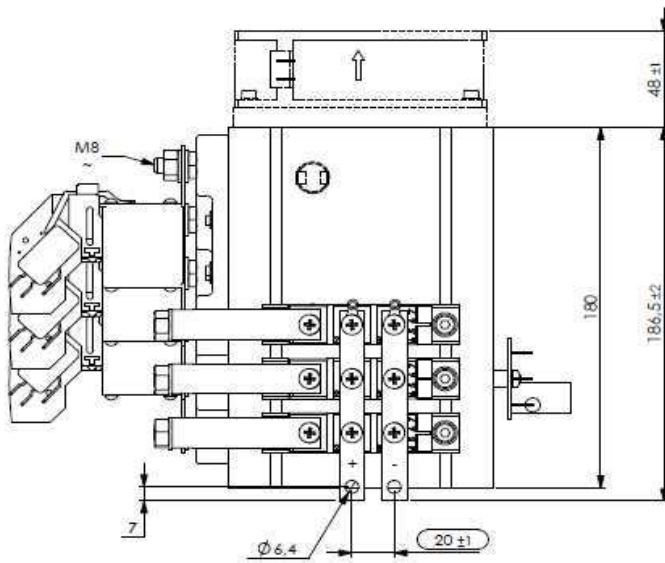
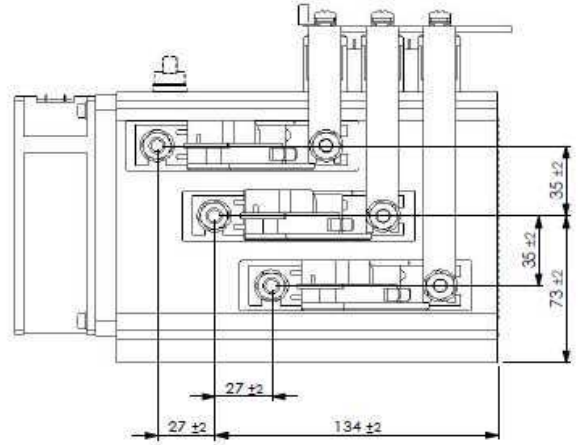
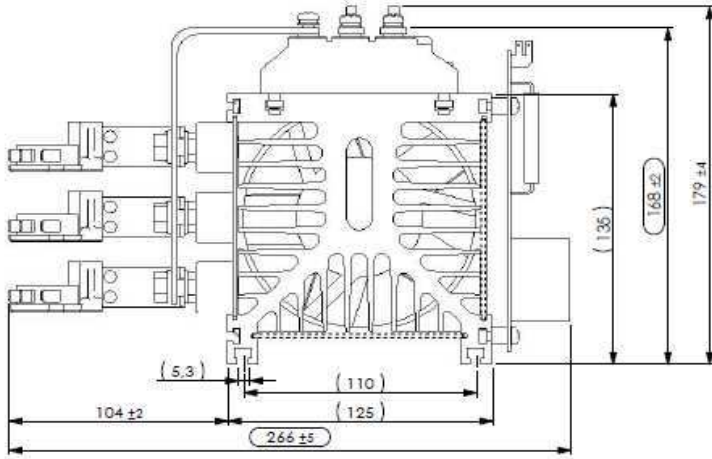

Dimensions

This technical information specifies semiconductor devices but promises no characteristics. No warranty or guarantee expressed or implied is made regarding delivery, performance or suitability.